

RECEIVED 27 JUL 1962

MARCH 1961

METALLIFACTURE LTD

BRITAIN'S MOST VERSATILE JACK MANUFACTURERS

JACK DIVISION CATALOGUE

VARIATIONS UNLIMITED

a 'Lift-up'



PLEASE RETURN TO :-
I. F. H. FARM MACHINERY
MARAZIOW

Works: Baldwin Street, Nottingham

Head Office: 240/246 Huntingdon Street, Nottingham

Telephone: Nottingham 51813/4/5

Telegrams: "Metallifac"

For Price List see back pages

METALLIFACTURE

JACKS



*T*HE Jacks illustrated in the following pages are constructed of best quality materials, the screw threads and general finish being of the highest order. The length of screws may be modified to suit customers' requirements. Should these standard types of Jacks not meet with customers' needs, we are always happy to design or modify to their individual specifications.

Parking and Jockey Wheel Jacks are, unless otherwise requested, supplied with the Standard nut. This, together with four other types of nut, which are also available, are illustrated separately.

Supplying as we do many of the leading Manufacturers every confidence can be placed in the design and quality of our products.

STANDARD TYPE NUT

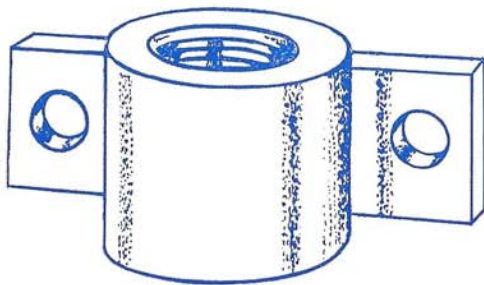

Material: Malleable Iron Nut. Bolt on side fastening.
Bolt holes. 4" between centres.

This Nut is the one that is normally supplied with all types of Agricultural or Parking Jacks in the P.J. and W.J. series.

TYPE 'D' NUT

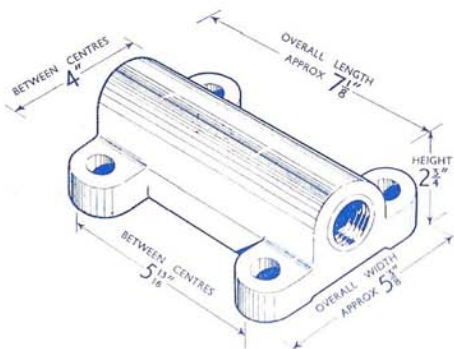

Other types stocked are illustrated on the next sheet, but special nuts can be produced to suit customers' own requirements at additional cost.

Manufactured by **METALLIFACTURE Ltd.**

Works: Baldwin Street, Nottingham

Offices: 240/246 Huntingdon Street, Nottingham

Telephone 51813/4/5

Telegrams "Metallifac"

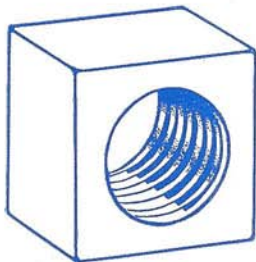

TYPE A

Material: Mild Steel
2" cube For welding to chassis

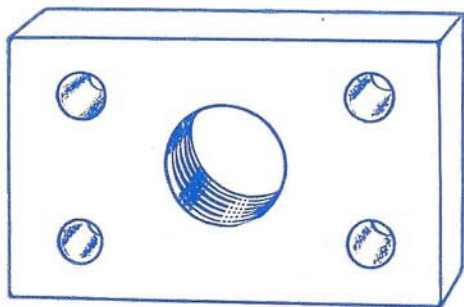

TYPE C

Material: Mild Steel
2" x 2½" x 4½" Bolt on.

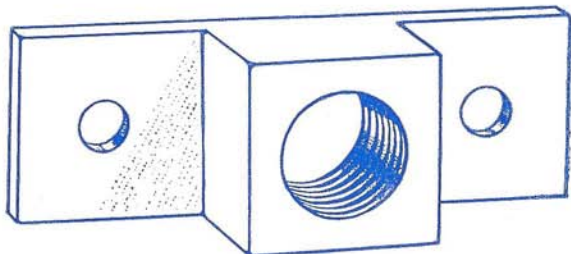

TYPE B

Material: Mild Steel. 6" Back Plate.
Can be bolted or welded between towbar

Manufactured by **METALLIFACTURE Ltd.**

Works: Baldwin Street, Nottingham

Offices: 240/246 Huntingdon Street, Nottingham

Telephone 51813/4/5

Telegrams "Metallifac"

Pattern C.J. /2

RATCHET BUMPER CAR JACK 23" LIFT (Max.)

Weight 7 lb. Capacity 20 cwt. 25 $\frac{1}{8}$ " overall height

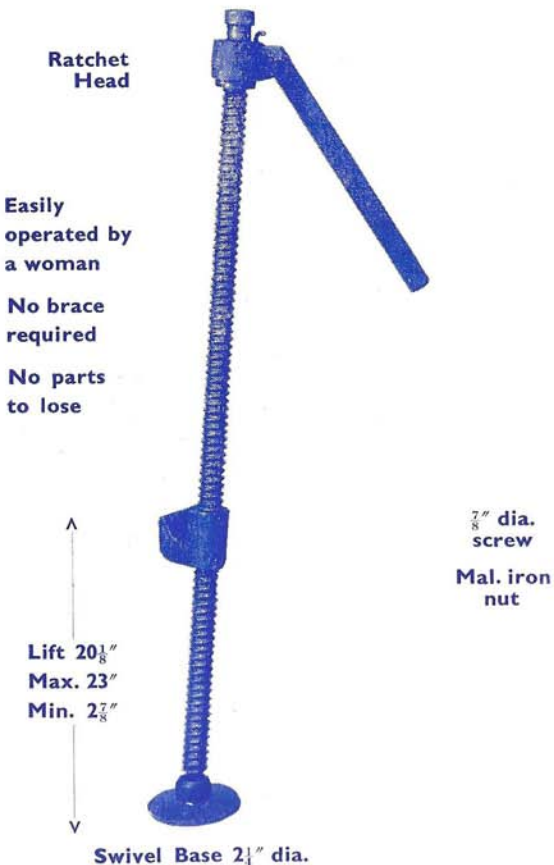

This Jack can be modified to suit the specifications of different chassis

Manufactured by **METALLIFACTURE Ltd.**

Works: Baldwin Street, Nottingham

Offices: 240/246 Huntingdon Street, Nottingham

Telephone 51813/4/5

Telegrams "Metallifac"

Pattern C.J./3

LIGHT TYPE TRAILER JACK

Weight 6 lb. Capacity 20 cwt. 20½" overall height

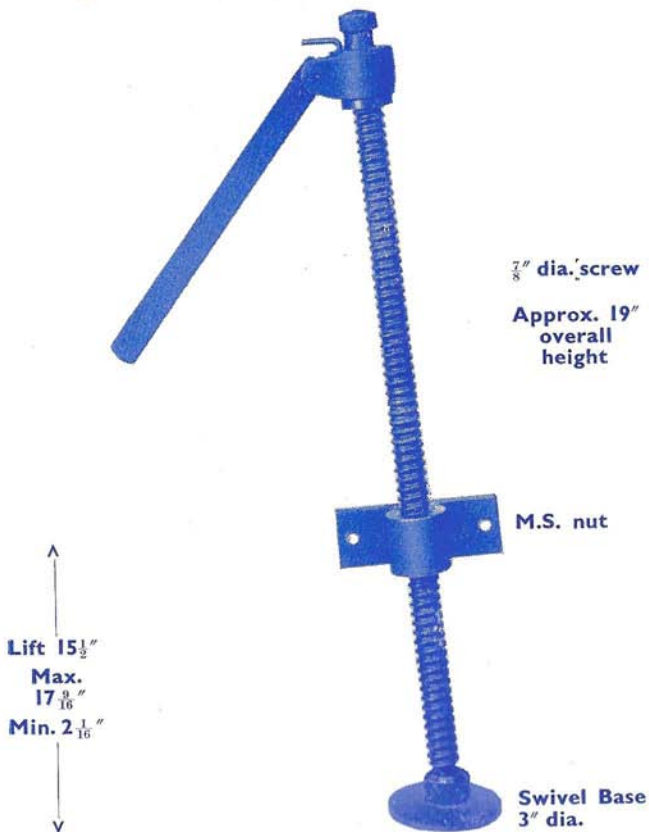

This Jack is available with various types of Nuts (see separate illustration) and also to customers' requirements

The Screw length may be varied

Manufactured by **METALLIFACTURE Ltd.**

Works: Baldwin Street, Nottingham

Offices: 240/246 Huntingdon Street, Nottingham

Telephone 51813/4/5

Telegrams "Metallifac"

Pattern C.J./4
BIPOD CAR JACK (Weight $6\frac{1}{2}$ lb., capacity 15 cwt.)

Ball thrust
race

Operated
by wheel
brace

$\frac{1}{2}$ " dia. screw

Mal. iron
nut

Lift
Max. $19\frac{1}{8}$ "
Min. 4"

Total
Height
 $21\frac{1}{2}$ "

← Base Length 9" →

The Jack has a patented self-aligning seating, allowing a direct vertical pull on whatever camber or gradient the car may be standing, and is fitted with a round hinge bar for use in round or square sockets, thus eliminating any twisting of the chassis bracket and preventing any undue strain on the nut.

Manufactured by **METALLIFACTURE Ltd.**

Works: Baldwin Street, Nottingham

Offices: 240/246 Huntingdon Street, Nottingham

Telephone 51813/4/5

Telegrams "Metallifac"

Pattern CJ/5
GEARED TYPE UNIFRAME JACK

Weight $7\frac{1}{2}$ lb. Capacity 20 cwt.

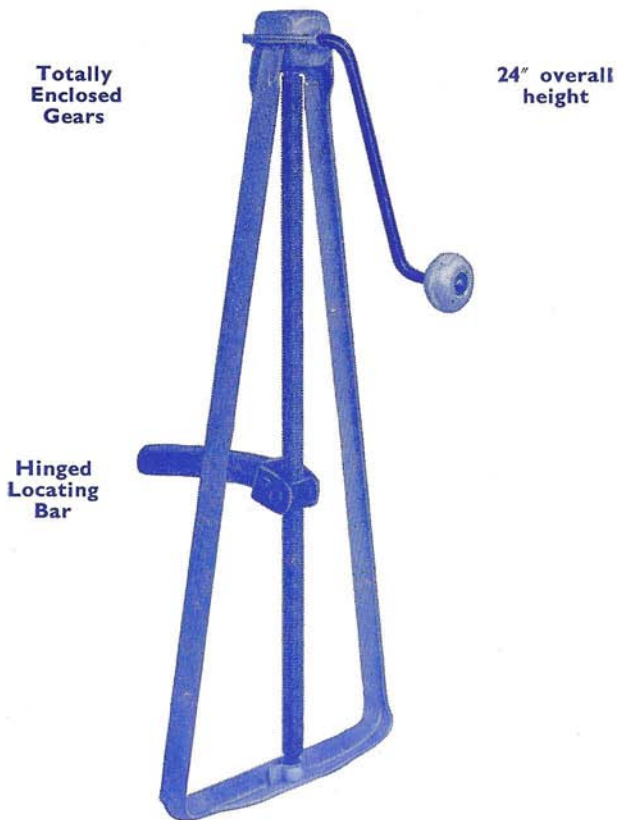

An easy to operate Side Lifting Jack in a one-piece frame construction.

Manufactured by **METALLIFACTURE Ltd.**

Works: Baldwin Street, Nottingham

Offices: 240/246 Huntingdon Street, Nottingham

Telephone 51813/4/5

Telegrams "Metallifac"

Pattern C.J./6

TUBULAR CAR JACK

Weight $4\frac{1}{2}$ lb. Capacity 20 cwt. $19\frac{3}{4}$ " overall height

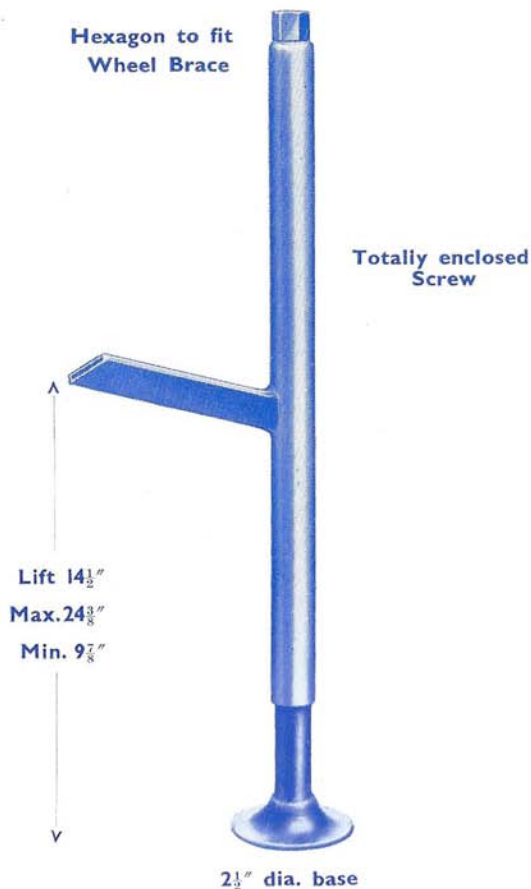

Manufactured by **METALLIFACTURE Ltd.**

Works: Baldwin Street, Nottingham

Offices: 240/246 Huntingdon Street, Nottingham

Telephone 51813/4/5

Telegrams "Metallifac"

Pattern C.J./7
AXLE STAND



Minimum height 11"
Maximum height 17"

Adjustable
in 1" steps

Any size
to order

Manufactured by **METALLIFACTURE Ltd.**
Works: Baldwin Street, Nottingham
Offices: 240/246 Huntingdon Street, Nottingham
Telephone 51813/4/5 Telegrams "Metallifac"

Pattern C.J./8A

GEARED BIPOD CAR JACK

Weight $7\frac{1}{2}$ lb. Capacity 25 cwt. Three Sizes

Alternative overall heights $20\frac{3}{8}$ " , $22\frac{7}{16}$ " , $23\frac{3}{8}$ "



Manufactured by **METALLIFACTURE Ltd.**

Works: Baldwin Street, Nottingham

Offices: 240/246 Huntingdon Street, Nottingham

Telephone 51813/4/5

Telegrams "Metallifac"

Pattern C.J./10

HEAVYWEIGHT SCISSOR TYPE CAR JACK

Weight 10 lb. Capacity 20 cwt.

Substantial Base

This step can be modified
to customers' requirements

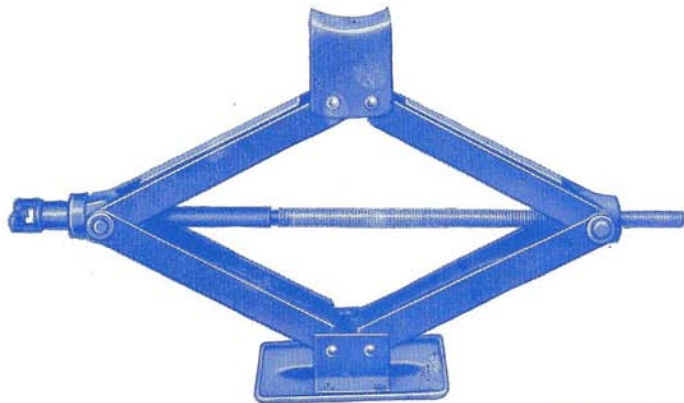

Operating Handle
included in Price

Lift $4\frac{1}{2}$ " to $18\frac{1}{2}$ "

Complete rigidity at any height
Particularly suitable for Caravans

Manufactured by **METALLIFACTURE Ltd.**

Works: Baldwin Street, Nottingham

Offices: 240/246 Huntingdon Street, Nottingham

Telephone 51813/4/5

Telegrams "Metallifac"

Pattern C.J./12A
UNIFRAME CAR JACK

Weight $6\frac{1}{2}$ lb. $19\frac{3}{8}$ " overall height. Capacity 20 cwt.

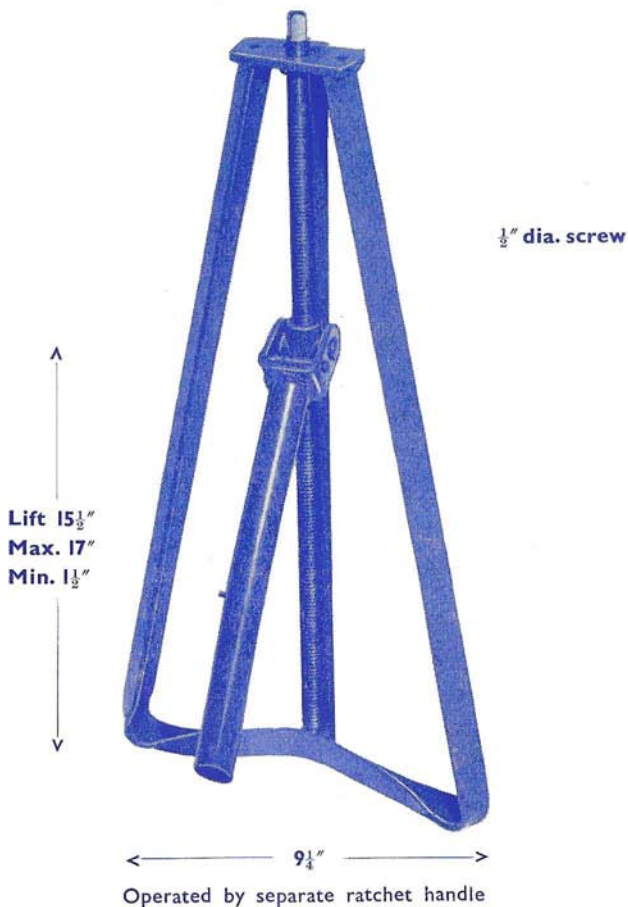

Manufactured by **METALLIFACTURE Ltd.**
Works: Baldwin Street, Nottingham
Offices: 240/246 Huntingdon Street, Nottingham
Telephone 51813/4/5 Telegrams "Metallifac"

Pattern C.J./15
LIGHTWEIGHT SCISSOR TYPE CAR JACK

Weight 5 lb. Capacity 15 cwt.

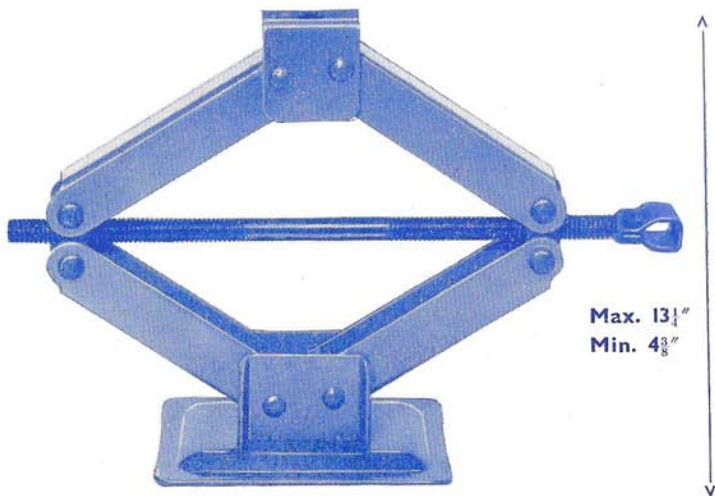

4" x 6" base. $\frac{9}{16}$ " dia. screw

Alternative steps can be designed to
suit customers special requirements

**A very sturdy and versatile Jack
supplied with operating handle**

Manufactured by **METALLIFACTURE Ltd.**

Works: Baldwin Street, Nottingham

Offices: 240/246 Huntingdon Street, Nottingham

Telephone 51813/4/5

Telegrams "Metallifac"

Pattern C.J./16

MODIFIED GEARED BIPOD CAR JACK

Weight $7\frac{1}{2}$ lb. Capacity 25 cwt. $23\frac{7}{8}$ " overall height

Totally enclosed Steel Gears

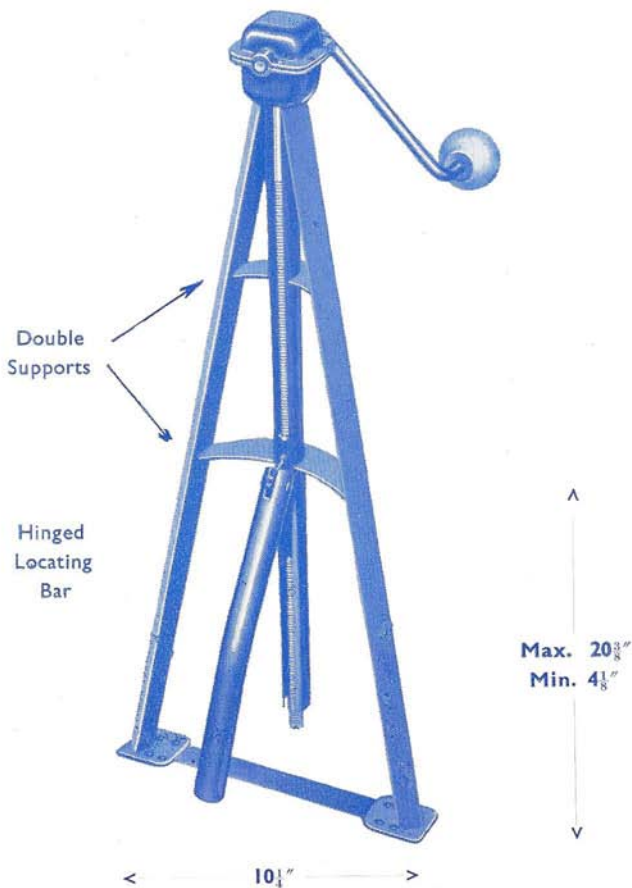

Manufactured by **METALLIFACTURE Ltd.**

Works: Baldwin Street, Nottingham

Offices: 240/246 Huntingdon Street, Nottingham

Telephone 51813/4/5

Telegrams "Metallifac"

Pattern C.J./17A

"TEE" FRAME HEAVY TYPE JACK

Weight $11\frac{1}{2}$ lb. Capacity 25 cwt.

Totally enclosed gears

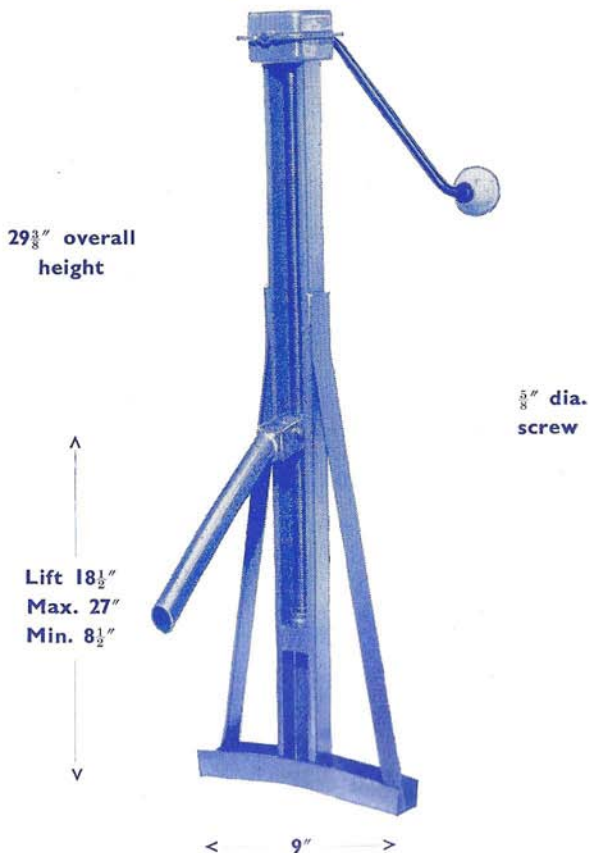

Manufactured by **METALLIFACTURE Ltd.**

Works: Baldwin Street, Nottingham

Offices: 240/246 Huntingdon Street, Nottingham

Telephone 51813/4/5

Telegrams "Metallifac"

Pattern C.J./17B

"TEE" FRAME LIGHT TYPE JACK

Weight 8 lb. Capacity 20 cwt.

Totally enclosed gears

23 $\frac{3}{8}$ " overall
height

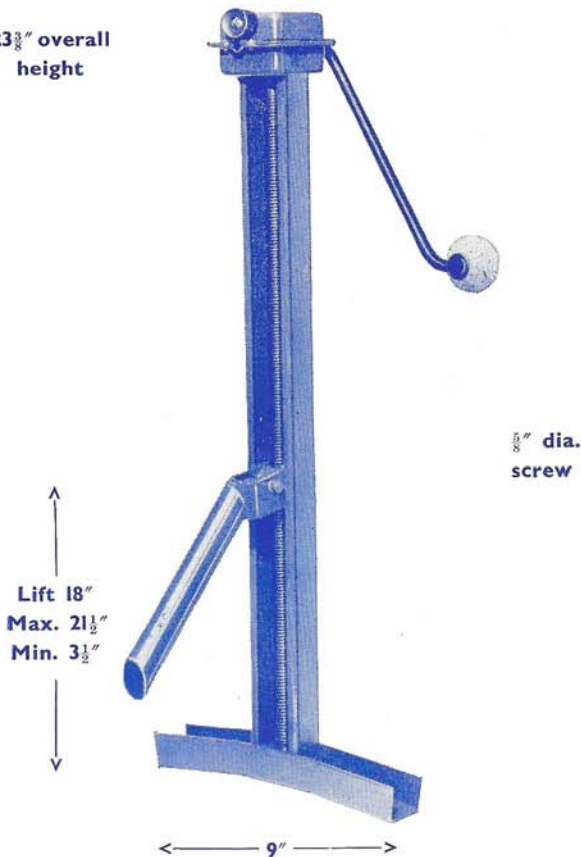

Manufactured by **METALLIFACTURE Ltd.**

Works: Baldwin Street, Nottingham

Offices: 240/246 Huntingdon Street, Nottingham

Telephone 51813/4/5

Telegrams "Metallifac"

Pattern W.J. / I
6" JOCKEY WHEEL JACK

Weight 28 lb.
Suitable for 3 ton
Trailer

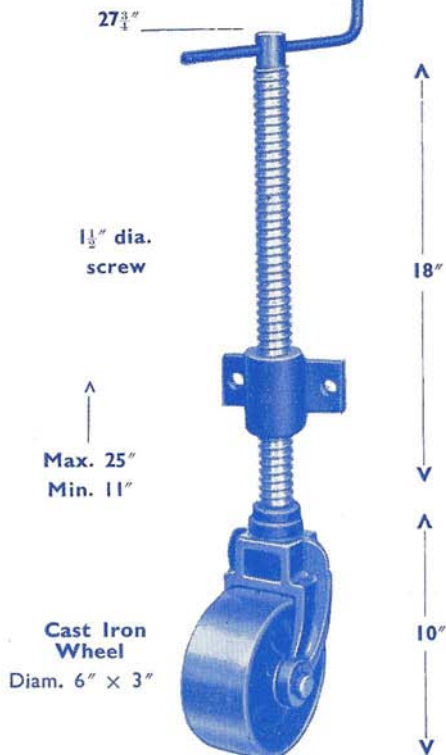

This Jack is available with various types of Nuts
(see separate illustration) and also to customers' requirements

The Screw length may be varied

Manufactured by **METALLIFACTURE Ltd.**

Works: Baldwin Street, Nottingham

Offices: 240/246 Huntingdon Street, Nottingham

Telephone 51813/4/5

Telegrams "Metallifac"

Pattern W.J./2
10" JOCKEY WHEEL JACK

Weight 38 lb.
Suitable for 4 ton trailer

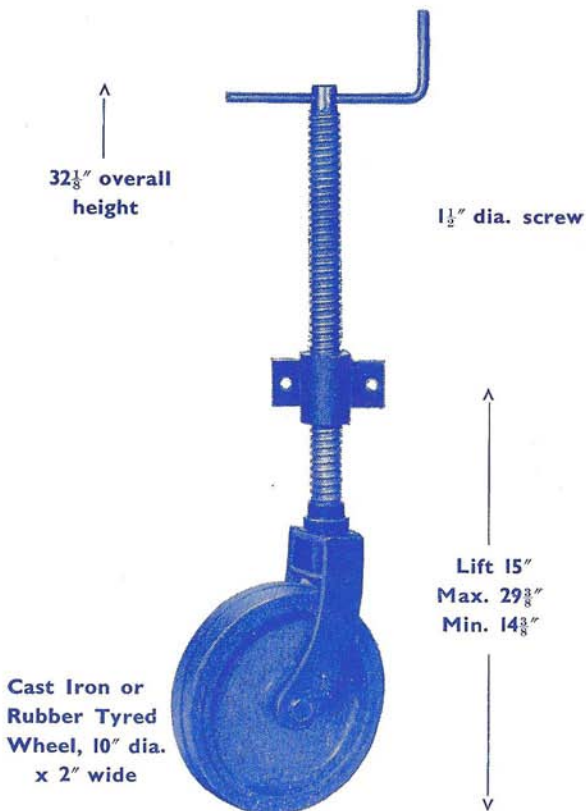

This Jack is available with various types of Nuts (see separate illustration) and also to customers' requirements

The Screw length may be varied

Manufactured by **METALLIFACTURE Ltd.**

Works: Baldwin Street, Nottingham

Offices: 240/246 Huntingdon Street, Nottingham

Telephone 51813/4/5

Telegrams "Metallifac"

Pattern W.J./3
12" JOCKEY WHEEL JACK

Weight 44 lb.
Suitable for 4 ton trailer

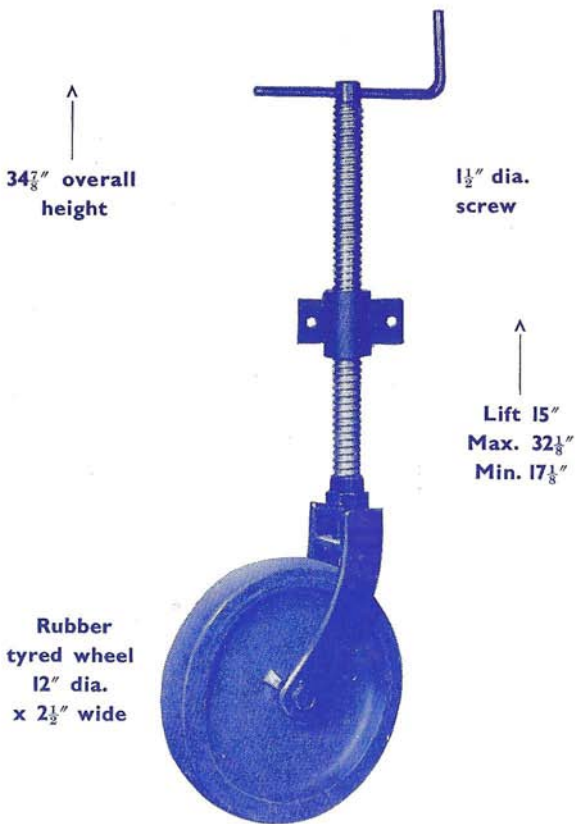

This Jack is available with various types of Nuts (see separate illustration) and also to customers' requirements

The Screw length may be varied

Manufactured by **METALLIFACTURE Ltd.**

Works: Baldwin Street, Nottingham

Offices: 240/246 Huntingdon Street, Nottingham

Telephone 51813/4/5

Telegrams "Metallifac"

Pattern W.J. / 4
6" DOUBLE JOCKEY WHEEL JACK

Weight 34 lb. Suitable for 3 ton Trailer

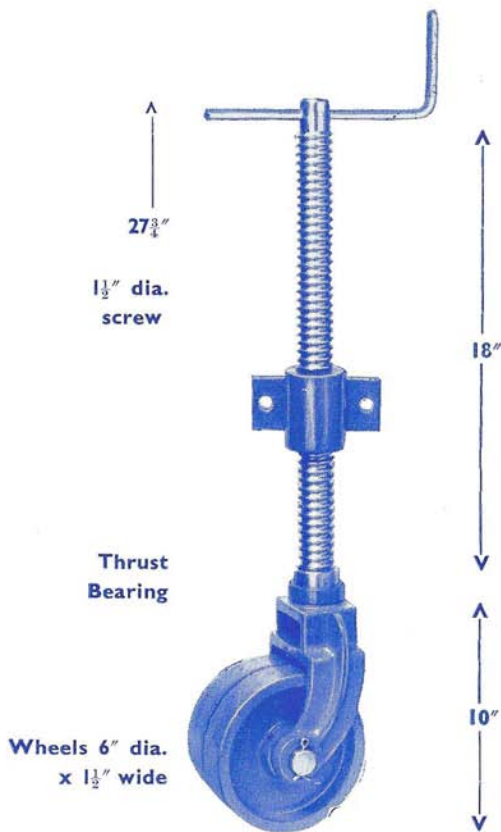

This Double Wheel Type facilitates very easy manœuvring

Manufactured by **METALLIFACTURE Ltd.**

Works: Baldwin Street, Nottingham

Offices: 240/246 Huntingdon Street, Nottingham

Telephone 51813/4/5

Telegrams "Metallifac"

Pattern W.J./5
8' TELESCOPIC JOCKEY WHEEL JACK

Weight 22 lb.
Suitable for 2 ton Trailer

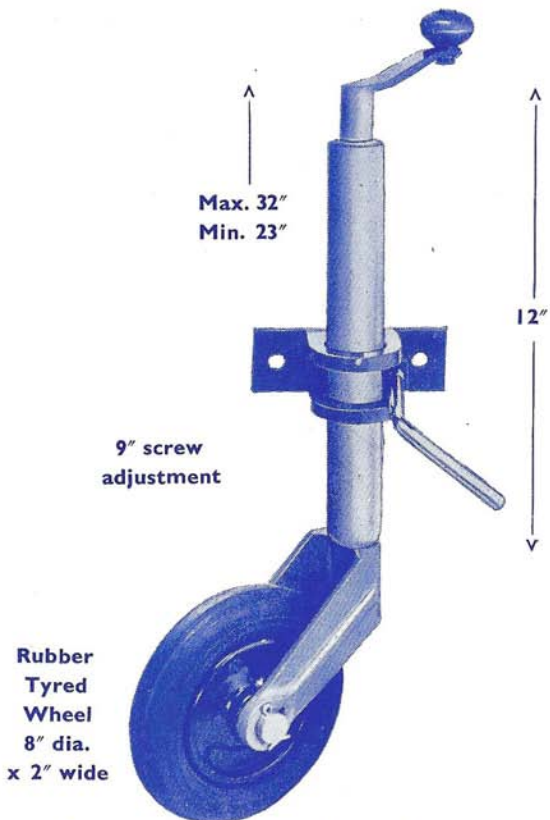

Totally enclosed Screw and Nut affording complete protection from dirt and weather

Bracket adjustable for height

Manufactured by **METALLIFACTURE Ltd.**

Works: Baldwin Street, Nottingham

Offices: 240/246 Huntingdon Street, Nottingham

Telephone 51813/4/5

Telegrams "Metallifac"

Pattern W.J./6
SCREWLESS JOCKEY JACK

Weight 19 lb.
Suitable for 2 ton Trailer

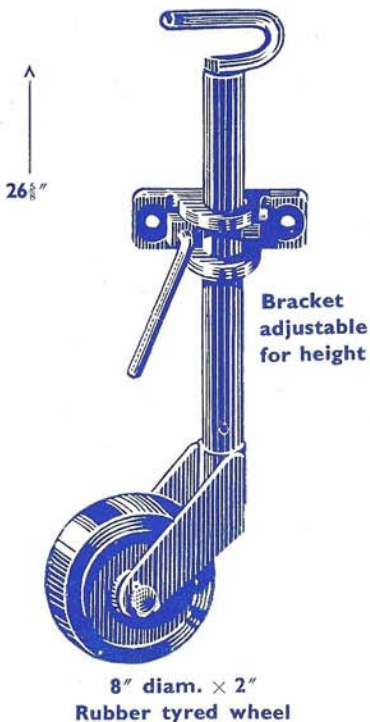

Similar to W.J./5 but without screw

Quick clamp adjustment for height

Manufactured by **METALLIFACTURE Ltd.**

Works: Baldwin Street, Nottingham

Offices: 240/246 Huntingdon Street, Nottingham

Telephone 51813/4/5

Telegrams "Metallifac"

Pattern P.J./I
FIXED BASE JACK
Weight 15 lb.
Suitable for 4 ton Trailer

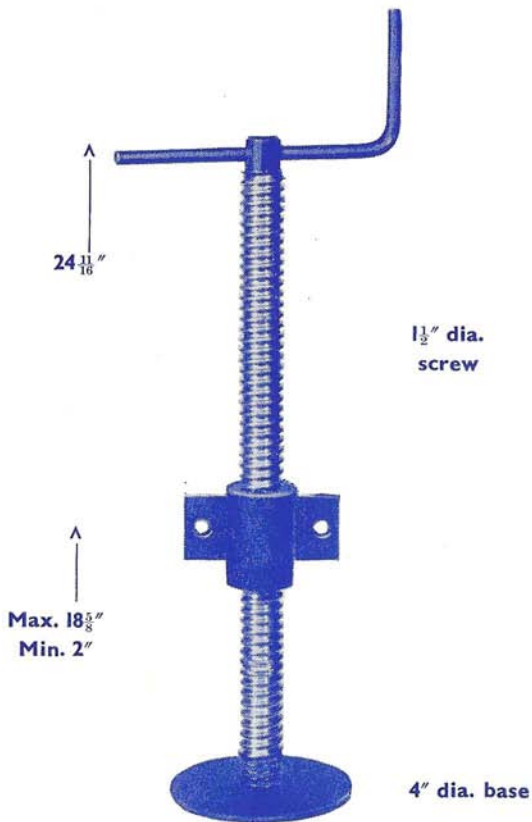

This Jack is available with various types of Nuts (see separate illustration) and also to customers' requirements
The Screw length may be varied

Manufactured by **METALLIFACTURE Ltd.**
Works: Baldwin Street, Nottingham
Offices: 240/246 Huntingdon Street, Nottingham
Telephone 51813/4/5 Telegrams "Metallifac"

Pattern P.J./2
TRAILER PARKING JACK
Weight 17 lb.
Suitable for 3 ton Trailer

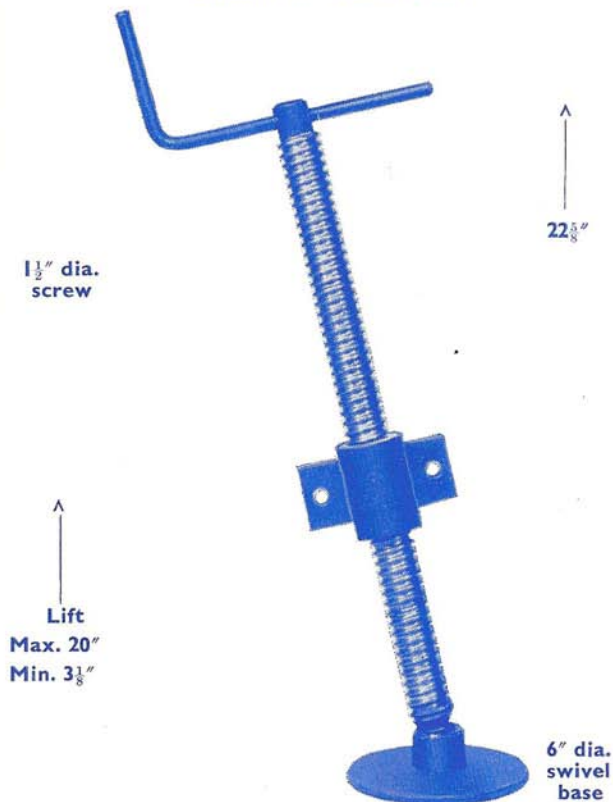

This Jack is available with various types of Nuts (see separate illustration) and also to customers' requirements

The Screw length may be varied

Supplied with Knuckle Thread which is particularly suitable where screw is exposed to elements.

Manufactured by **METALLIFACTURE Ltd.**

Works: Baldwin Street, Nottingham

Offices: 240/246 Huntingdon Street, Nottingham

Telephone 51813/4/5

Telegrams "Metallifac"

Pattern P.J./3
EXTRA HEAVY DUTY JACK
Weight 22 lb.
Suitable for 5 ton Trailer

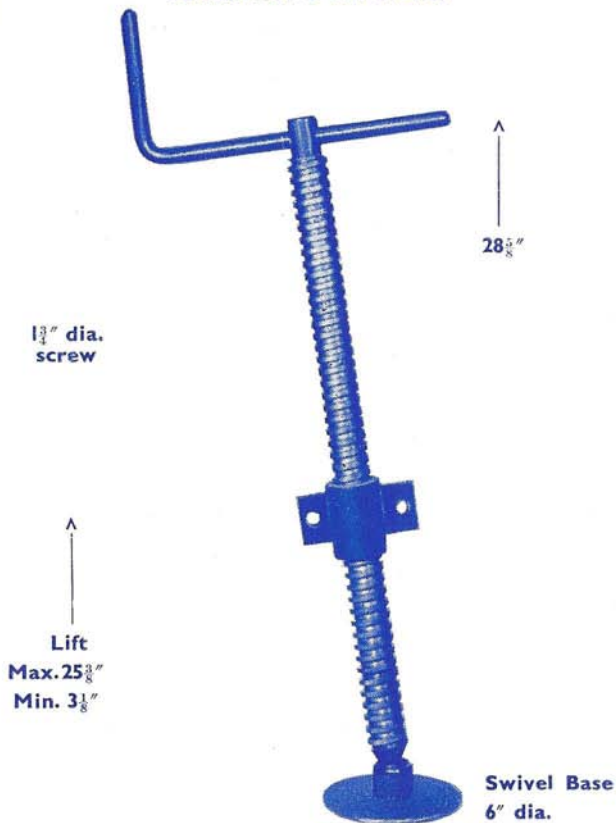

This Jack is available with various types of Nuts
(see separate illustration) and also to customers' requirements

The Screw length may be varied

Manufactured by **METALLIFACTURE Ltd.**

Works: Baldwin Street, Nottingham

Offices: 240/246 Huntingdon Street, Nottingham

Telephone 51813/4/5

Telegrams "Metallifac"

P.J./UTILITY HEAVY DUTY JACK

Weight 23 lb.
Suitable for 5 ton Trailer

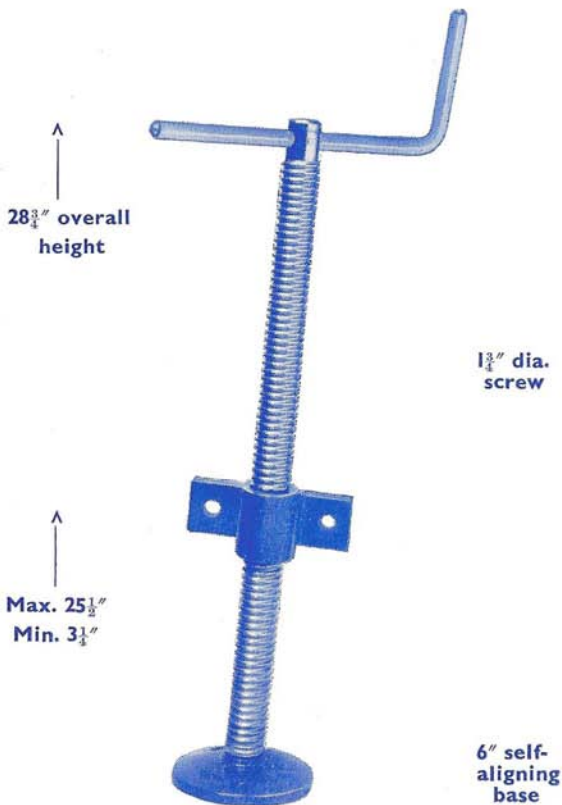

An alternative to our PJ/3 type but with
a less expensive base design

Manufactured by **METALLIFACTURE Ltd.**

Works: Baldwin Street, Nottingham

Offices: 240/246 Huntingdon Street, Nottingham

Telephone 51813/4/5

Telegrams "Metallifac"

Pattern P.J./4
CARAVAN PARKING JACK
Suitable for Vans up to 35 cwt.

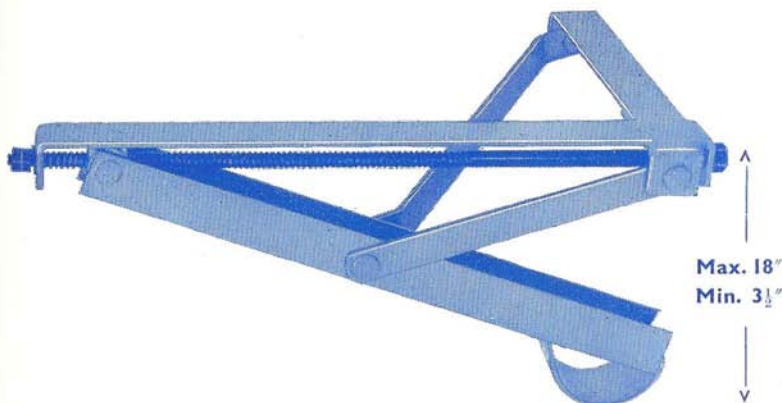
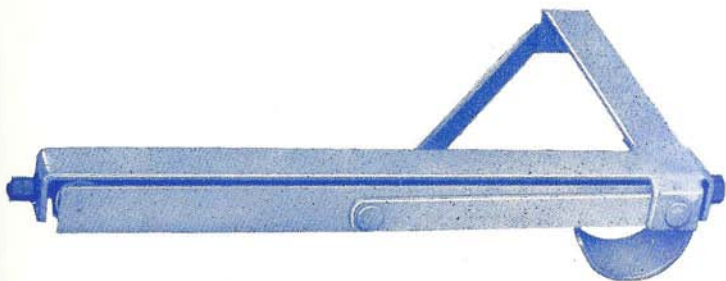

Manufactured by **METALLIFACTURE Ltd.**
Works: Baldwin Street, Nottingham
Offices: 240/246 Huntingdon Street, Nottingham
Telephone 51813/4/5 Telegrams "Metallifac"

Pattern P.J. / 5
TUBULAR PARKING JACK

Weight 7 lb.
Suitable for 3 ton Trailer

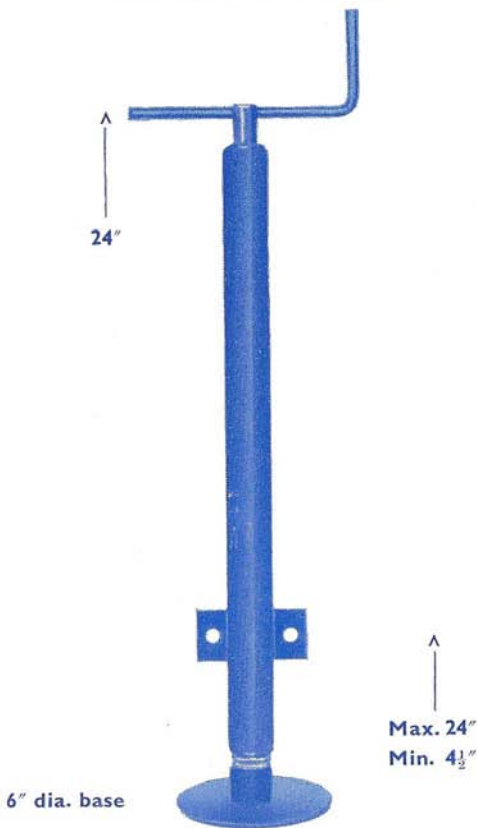

An improved, totally enclosed Parking Jack suitable for all types of Farm implements and Trailers, affording protection from weather and dirt.

Manufactured by **METALLIFACTURE Ltd.**

Works: Baldwin Street, Nottingham

Offices: 240/246 Huntingdon Street, Nottingham

Telephone 51813/4/5

Telegrams "Metallifac"

Pattern P.J./6
DUAL PURPOSE JACK

Weight 12 lb.
26" overall height closed. Suitable for 30 cwt. Trailer

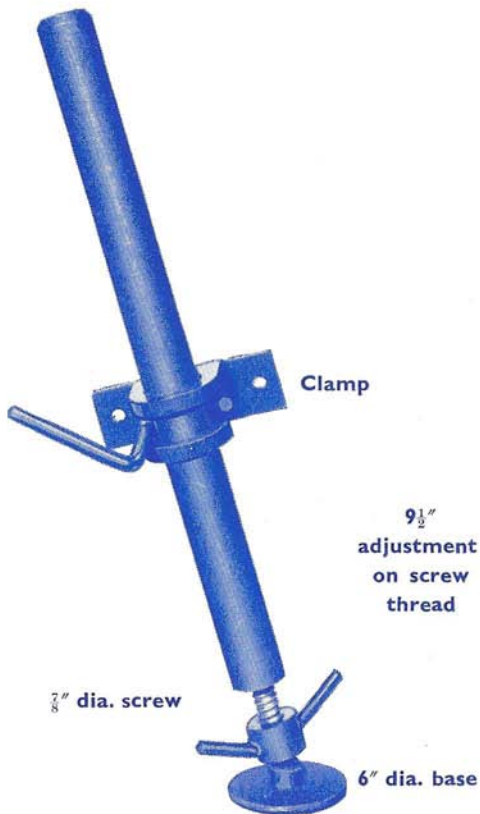

Quick clamp adjustment for height with
final screw adjustment

Manufactured by **METALLIFACTURE Ltd.**
Works: Baldwin Street, Nottingham
Offices: 240/246 Huntingdon Street, Nottingham
Telephone 51813/4/5 Telegrams "Metallifac"

Pattern P.J./7
PARKING PROP JACK

Weight 24 lb.

Suitable for 3 ton Trailer

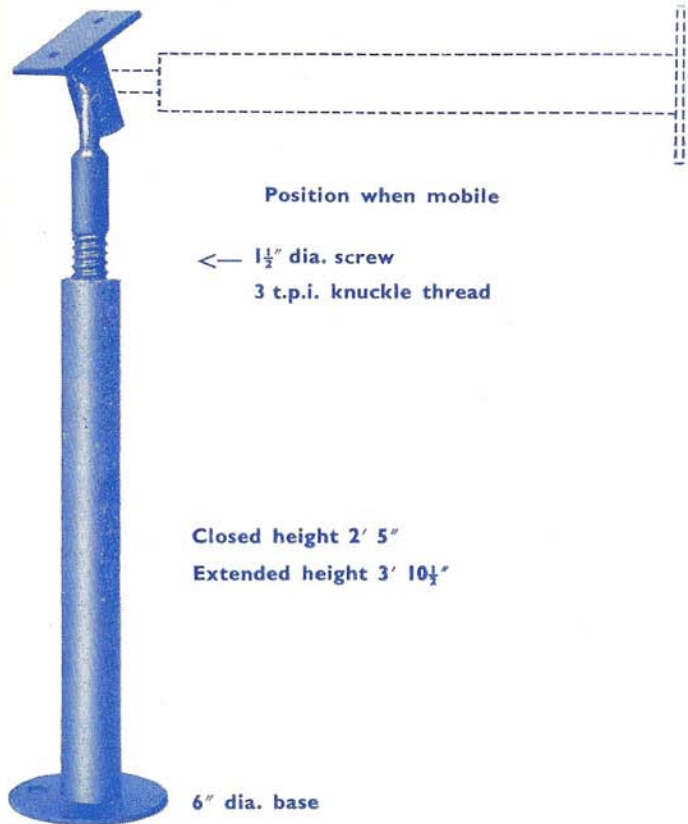

Adaptable to all Trailer and Caravan Chassis,
Dimensions can be varied

Manufactured by **METALLIFACTURE Ltd.**

Works: Baldwin Street, Nottingham

Offices: 240/246 Huntingdon Street, Nottingham

Telephone 51813/4/5

Telegrams "Metallifac"

Pattern P.J./8

LEVELLING JACK

Weight 15 lb. Capacity 40 cwt.

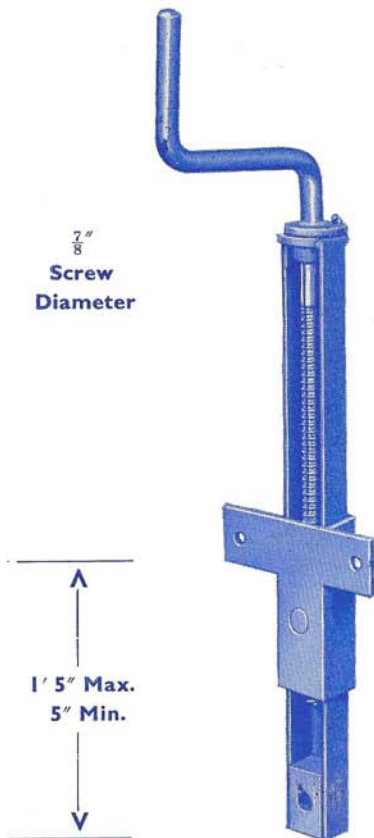

This Jack is used for levelling agricultural implements and is either fitted with a wheel or flat base. When fitted with wheel the Jack can be used whilst implement is mobile.

Manufactured by **METALLIFACTURE Ltd.**

Works: Baldwin Street, Nottingham

Offices: 240/246 Huntingdon Street, Nottingham

Telephone 51813/4/5

Telegrams "Metallifac"

Pattern T.J. / I
TRACTOR JACK

Weight 15 lb. Capacity 50 cwt.



Max. 27"
Min. 15½"

Rigid Base 5½" diameter

Manufactured by **METALLIFACTURE Ltd.**

Works: Baldwin Street, Nottingham

Offices: 240/246 Huntingdon Street, Nottingham

Telephone 51813/4/5

Telegrams "Metallifac"

Pattern S.L.J./I
SINGLE LIFT JACK
Weight 4 lb. Capacity 12 cwt.

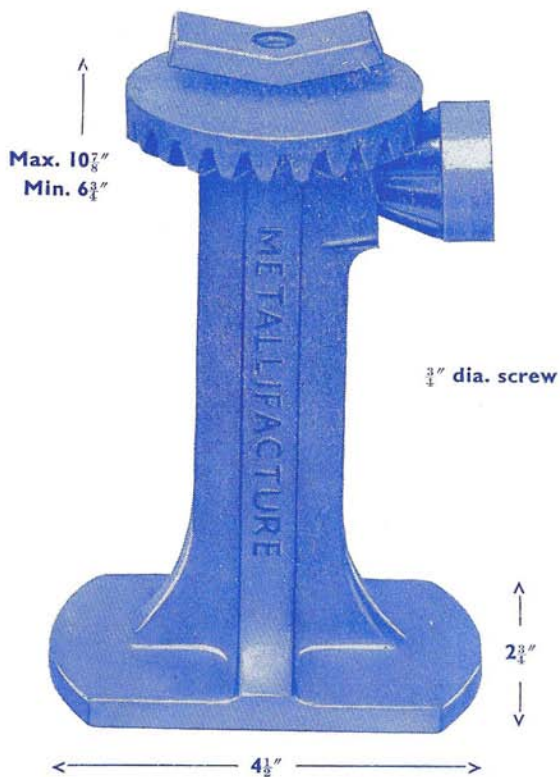

Supplied with operating handle

Manufactured by **METALLIFACTURE Ltd.**
Works: Baldwin Street, Nottingham
Offices: 240/246 Huntingdon Street, Nottingham
Telephone 51813/4/5 Telegrams "Metallifac"

Pattern DLJ 2A
RATCHET TYPE DOUBLE LIFT JACK

Weight 12 lb. Capacity 40 cwt.

Min. height
6 $\frac{3}{4}$ "

Max. height
15 $\frac{3}{8}$ "



Base 6" x 3 $\frac{1}{2}$ "

Supplied with operating handle

A sturdy and reliable Jack with a ratchet operation.

Widely used for heavy cars, vans and lorries.

Manufactured by **METALLIFACTURE Ltd.**

Works: Baldwin Street, Nottingham

Offices: 240/246 Huntingdon Street, Nottingham

Telephone 51813/4/5

Telegrams "Metallifac"

3 TON & 15 CWT NOT YET IN PRODUCTION

Pattern DLJ/3A
WORM OPERATED DOUBLE LIFT JACK
(3 sizes)



The worm action makes this Jack the easiest to operate and a woman could comfortably lift a van with little effort.

ALTERNATIVE DIMENSIONS

Capacity 3T. Large
 $1\frac{7}{16}$ " o/screw, min. height 7".
 $1\frac{1}{16}$ " i/screw, max. height 15".
Base 5" dia.

Capacity 2T. Medium
 $1\frac{1}{16}$ " o/screw, min. height $6\frac{7}{8}$ ".
 $\frac{11}{16}$ " i/screw, max. height $15\frac{3}{8}$ ".
Base $4\frac{1}{2}$ " dia.

Capacity 15 cwt. Small
Min. height $4\frac{3}{4}$ "; max. height $10\frac{1}{4}$ "; base 3".

Manufactured by **METALLIFACTURE Ltd.**

Works: Baldwin Street, Nottingham

Offices: 240/246 Huntingdon Street, Nottingham

Telephone 51813/4/5

Telegrams "Metallifac"

These Jacks are now obsolete but can be produced if a quantity is required.

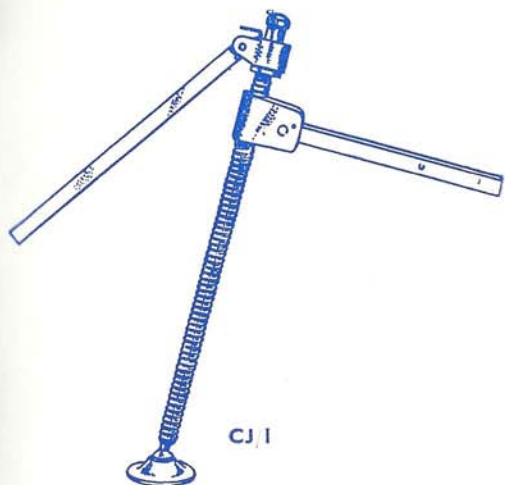

CJ 1



CJ/13

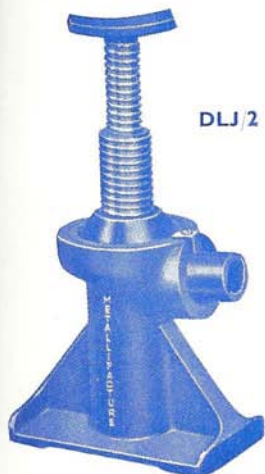

DLJ/2



CJ 9

Manufactured by **METALLIFACTURE Ltd.**

Works: Baldwin Street, Nottingham

Offices: 240/246 Huntingdon Street, Nottingham

Telephone 51813/4/5

Telegrams "Metallifac"

These Jacks are now obsolete but can be produced if a quantity is required.



CJ/8



CJ/12

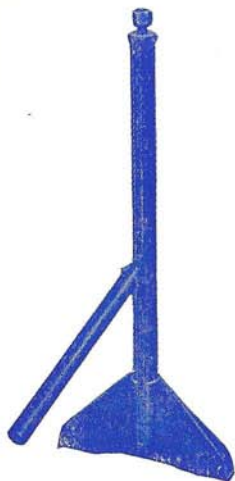

CJ/11



CJ/14

Manufactured by **METALLIFACTURE Ltd.**

Works: Baldwin Street, Nottingham

Offices: 240/246 Huntingdon Street, Nottingham

Telephone 51813/4/5

Telegrams "Metallifac"

Pattern T.G./1
SINGLE LIFT LIGHT DUTY TIPPING
GEAR LIFT 4' 3"
Capacity 1½ tons

Heavy Duty Type, as
illustrated, but with
self-alignment Nut

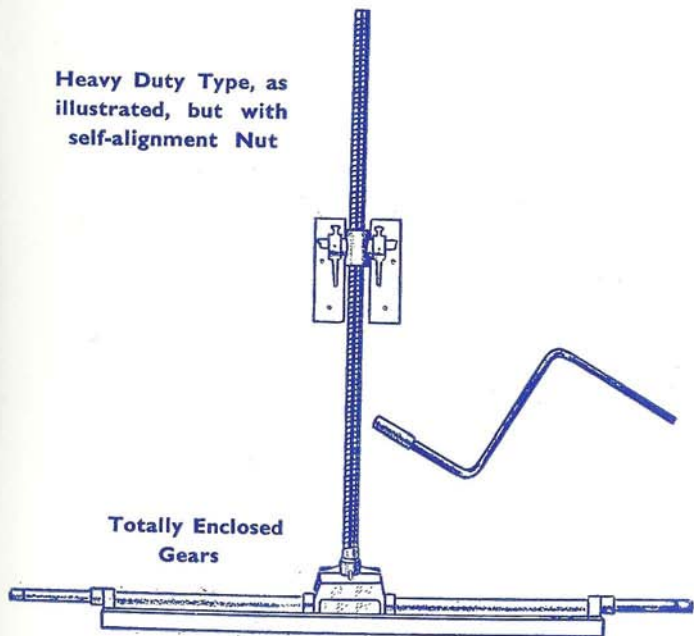

Length of Base 4' 6". Length of Winding Shaft 5' 6"

Available with various lengths of Screw
to meet Customers' requirements

Manufactured by **METALLIFACTURE Ltd.**
Works: Baldwin Street, Nottingham
Offices: 240/246 Huntingdon Street, Nottingham
Telephone 51813/4/5 Telegrams "Metallifac"

Pattern T.G./2

DOUBLE LIFT TIPPING GEAR — LIFT 4' 5 $\frac{1}{2}$ "

Capacity 2 $\frac{1}{3}$ tons

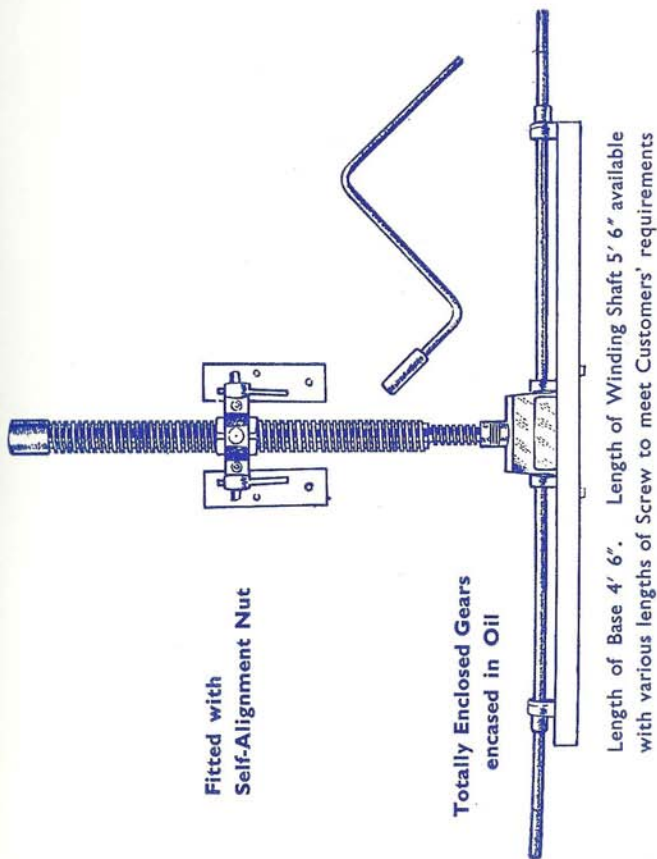

Manufactured by **METALLIFACTURE Ltd.**

Works: Baldwin Street, Nottingham

Offices: 240/246 Huntingdon Street, Nottingham

Telephone 51813/4/5

Telegrams "Metallifac"

Pattern T.G./3
LIGHTWEIGHT TIPPING GEAR
Double Lift 4' 10"

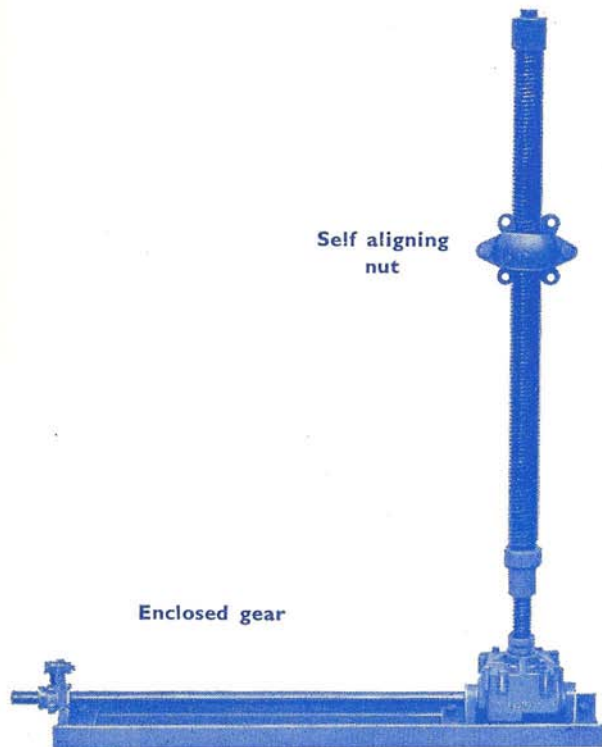

Only made in quantity to customers' special orders

Manufactured by **METALLIFACTURE Ltd.**
Works: Baldwin Street, Nottingham
Offices: 240/246 Huntingdon Street, Nottingham
Telephone 51813/4/5 Telegrams "Metallifac"

METALLIFACTURE LIMITED

PRICE LIST—March 1961

CAR JACKS		Retail Price			
Pattern		£	s.	d.	
C.J./2	Ratchet Bumper Car Jack	1	6	4	
C.J./3	Light Type Trailer Jack	2	4	6	
C.J./4	Bipod Car Jack	1	1	4	
C.J./5	Geared Type Uniframe Jack	1	9	3	
C.J./6	Tubular Car Jack	1	2	4	
C.J./7	Axle Stand	Price quoted on size reqd.			
C.J./8a	Geared Bipod Car Jack	1	15	4	
C.J./10	Heavyweight Scissor Type Car Jack, c/w handle	1	18	7	
C.J./12a	Uniframe Car Jack, c/w handle	1	5	0	
C.J./15	Lightweight Scissor Type Car Jack, c/w handle	1	3	2	
C.J./16	Modified Geared Bipod Car Jack	2	0	5	
C.J./17a	'Tee' Frame Heavy Type Jack	2	10	9	
C.J./17b	'Tee' Frame Light Type Jack	2	5	9	
WHEEL JACKS					
W.J./1	6" Jockey Wheel Jack	4	4	6	
	Can be supplied with 6" x 2" rubber tyred wheel extra		18	2	
W.J./2	10" Jockey Wheel Jack	6	1	3	
W.J./3	12" Jockey Wheel Jack	6	18	10	
W.J./4	6" Double Jockey Wheel Jack	4	13	9	
	Can be supplied with 6" x 2" rubber tyred wheels extra		1	16	4
W.J./5	8" Telescopic Jockey Wheel Jack	5	9	6	
W.J./6	Screwless Jockey Jack	4	18	4	
	Any of the W.J. Series can be supplied with 1 3/4" dia. screw extra		6	0	
PARKING JACKS					
P.J./1	Fixed Based Jack	2	12	11	
P.J./2	Trailer Parking Jack	2	16	2	
P.J./3	Extra Heavy Duty Jack	3	17	2	
P.J./Utility	Utility Heavy Duty Jack	3	6	0	
P.J./4	Caravan Parking Jack (per set of 4 complete with handle)	4	16	8	
P.J./5	Tubular Parking Jack	2	18	0	
P.J./6	Dual Purpose Jack	3	12	2	
P.J./7	Parking Prop Jack	4	2	6	
P.J./8	Levelling Jack	4	2	6	
T.J./1	Tractor Jack	1	16	9	
S.L.J./1	Single Lift Jack, c/w handle		14	3	
D.L.J./2a	Ratchet Type Double Lift Jack, c/w handle	1	15	0	
D.L.J./3a	Worm Operated Double Lift Jack				
	Large	1	18	4	
	Medium	1	13	4	
	Small	1	5	0	

ALL CARRIAGE CHARGES EXTRA

METALLIFACTURE LIMITED

PRICE LIST—March 1961

NUTS

Pattern					£	s.	d.
Standard Malleable Iron Nut	9	6	
Type A 2" Cube Mild Steel Nut	9	6	
Type B 6" Mild Steel Back Plate Nut	10	6	
Type C 2" x 2 $\frac{3}{4}$ " x 4 $\frac{1}{2}$ " Mild Steel Bolt on Nut	10	0	
Type D 7 $\frac{1}{2}$ " x 5 $\frac{3}{8}$ " (approx.) Cast Iron Bolt on Nut	18	0	

TIPPING GEARS

T.G./1	Single Lift Tipping Gear	15	4	6
	Heavy Duty	1	18	0
T.G./2	Double Lift Tipping Gear 4' 6"	20	5	6
	Double Lift Tipping Gear 5' 0"	20	19	0
T.G./3	Light Weight Tipping Gear Double Lift 4' 10"	<i>Price on application</i>		
All Tipping Gears can be supplied with extra screw lengths							
T.G./1	Extra for 6" Lift	5	0	
T.G./2	Extra for 6" Lift	15	0	

EXTRAS

Locking Clip for Parking Jack	2	9
Additional Handles for Tipping Gears	9	6

HINGE BARS AND BRACKETS

Size	1 $\frac{1}{4}$ "	1 $\frac{3}{8}$ "	1 $\frac{1}{2}$ "
Price	47/8	51/5	59/2

(Brackets only 10/6)

ALL CARRIAGE CHARGES EXTRA

